

M9N/M9P/M9B, Solid State Switch, Direct Mounting, Grommet, In-line D-M9PL

Data Sheet

SMC offers a variety of auto switches for actuators and air grippers.; Solid state switches are available in a general purpose type or with 2-color indication, which allows the optimum operating position to be determined by the color of the light.; Solid state switches are also available in 2-color indication with diagnostic output, water resistant 2-color indication, built-in OFF-delay timer (200 ms), magnetic field resistant, heat resistant and wide range detection configurations.; Various lead wire lengths are available.

Standard Specifications

Model	3-wire, PNP
Lead Wire Length	3 m
Conform to the European RoHS Directive	Conform
Approvals	CE
Electrical entry direction	In-line
Applicable load	IC circuit, Relay, PLC
Load current	40 mA or less
Internal voltage drop	0.8 V or less at 10 mA (2v or less at 40 mA)
Wiring type	3-wire
Power supply	5, 12, 24 VDC (4.5 to 28 V)
Output type	PNP
Current consumption	10 mA or less
Leakage current	100 A or less at 24 VDC
Weight	0.041 kg

Dimensions

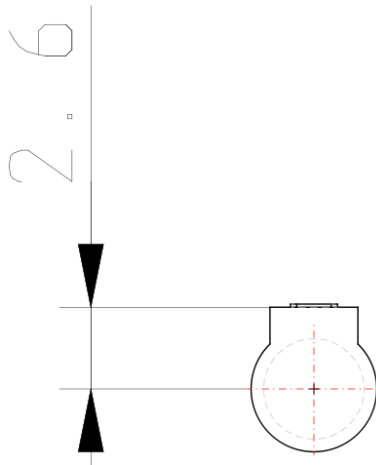
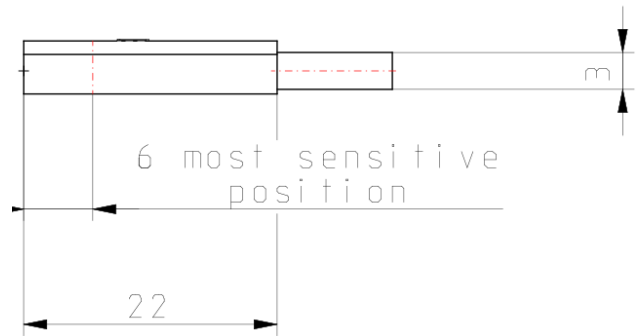
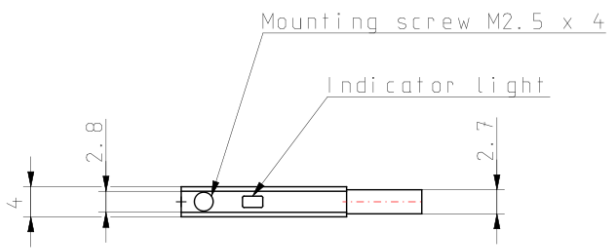

Additional information

Catalogue	AutoSwitch-guide-A_EU.pdf
Declaration of Conformity - Before April 2016 - manufacturing batch codes UQ backwards	DoC_D-x_TFG0001-G.pdf
Installation Manuals	IMM_D-M9x-13849_TFQ39EN.pdf